

LOC		DIST		REVISIONS			
P	LTR	DESCRIPTION	DATE	DMN	APVD		
G		ECO-07-012898	27JUN07	KW	DB		

- MATERIAL:
CONNECTOR: POLYESTER UL94V-0 (YELLOW).
CONTACTS: 0.30[.012] THK COPPER ALLOY.
 - CONTACT ACCEPT #20 AWG WIRE WITH 2.41[.095] MAXIMUM INSULATION DIAMETER.
 - CONNECTOR MATES WITH 1.57±0.20[.062±.008] THICK PC BOARD.
 - HOUSING FEATURES: FEED-THRU, STANDARD MOUTH WITH MOUNTING EARS.
- △ CONTACT FINISH: BRIGHT TIN-LEAD 0.00203[.000080] MIN THK.
 △ CONTACT FINISH: MATTE WHISKER MITIGATED TIN 0.00203[.000080] MIN THICKNESS OVER NICKEL UNDERPLATE.

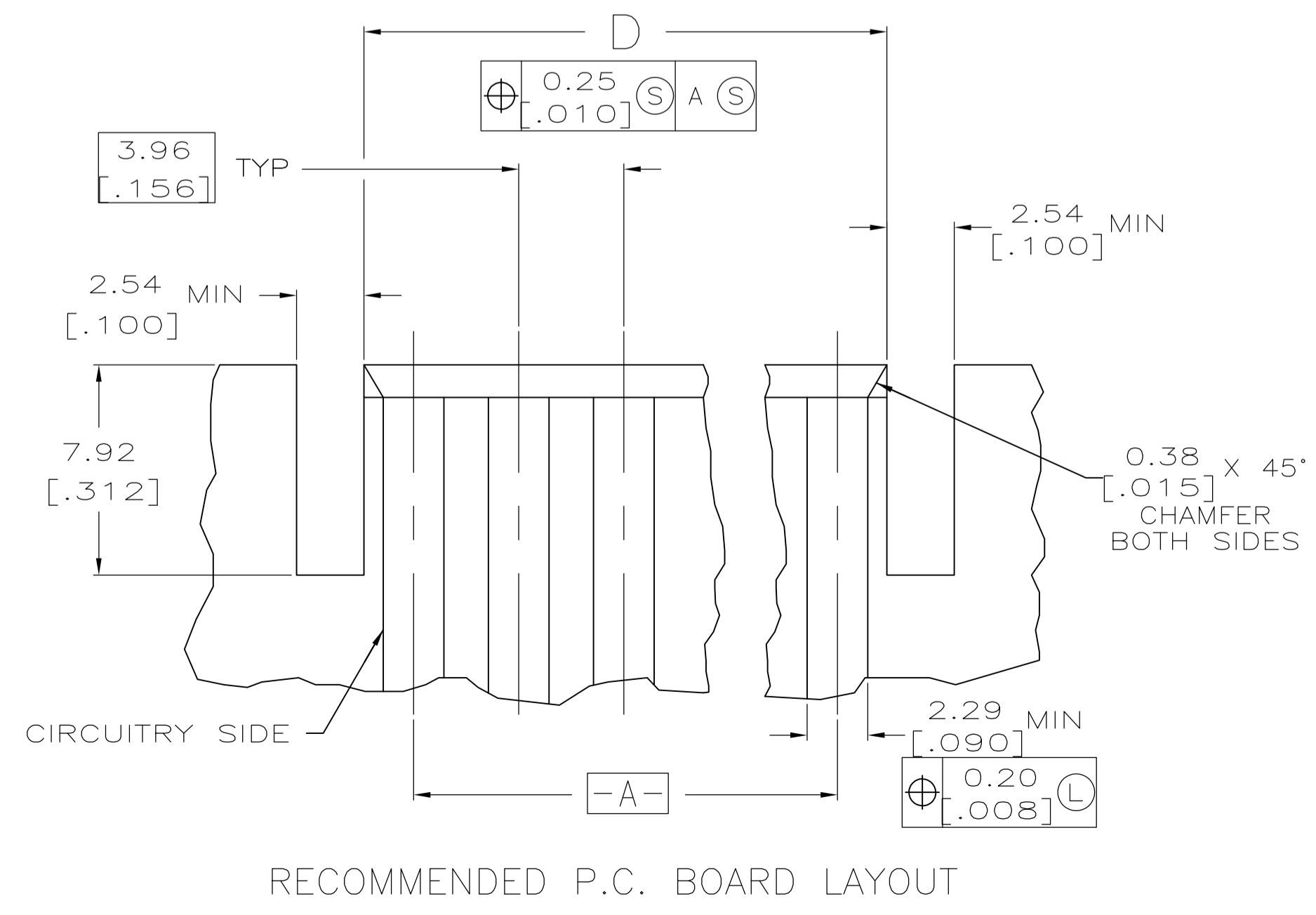

CONTACT FINISH	D	C	B	A	NO. OF CIRCUITS	PART NUMBER
△	95.50 [3.760]	114.91 [4.524]	106.73 [4.202]	95.91 [3.776]	24	5-641289-4
	91.54 [3.604]	110.95 [4.368]	102.77 [4.046]	91.95 [3.620]	23	5-641289-3
	87.58 [3.448]	106.98 [4.212]	98.81 [3.890]	87.99 [3.464]	22	5-641289-2
	83.62 [3.292]	103.02 [4.056]	94.84 [3.734]	84.02 [3.308]	21	5-641289-1
	79.65 [3.136]	99.06 [3.900]	90.88 [3.578]	80.06 [3.152]	20	5-641289-0
	71.73 [2.824]	91.14 [3.588]	82.96 [3.266]	72.14 [2.840]	18	4-641289-8
	59.84 [2.356]	79.25 [3.120]	71.07 [2.798]	60.25 [2.372]	15	4-641289-5
	47.96 [1.888]	67.36 [2.652]	59.18 [2.330]	48.36 [1.904]	12	4-641289-2
	36.07 [1.420]	55.47 [2.184]	47.29 [1.862]	36.47 [1.436]	9	3-641289-9
	24.18 [.952]	43.59 [1.716]	35.41 [1.394]	24.59 [.968]	6	3-641289-6
	12.29 [.484]	31.70 [1.248]	23.52 [.926]	12.70 [.500]	3	3-641289-3
	△	95.50 [3.760]	114.91 [4.524]	106.73 [4.202]	95.91 [3.776]	24
91.54 [3.604]		110.95 [4.368]	102.77 [4.046]	91.95 [3.620]	23	2-641289-3
87.58 [3.448]		106.98 [4.212]	98.81 [3.890]	87.99 [3.464]	22	2-641289-2
83.62 [3.292]		103.02 [4.056]	94.84 [3.734]	84.02 [3.308]	21	2-641289-1
79.65 [3.136]		99.06 [3.900]	90.88 [3.578]	80.06 [3.152]	20	2-641289-0
71.73 [2.824]		91.14 [3.588]	82.96 [3.266]	72.14 [2.840]	18	1-641289-8
59.84 [2.356]		79.25 [3.120]	71.07 [2.798]	60.25 [2.372]	15	1-641289-5
47.96 [1.888]		67.36 [2.652]	59.18 [2.330]	48.36 [1.904]	12	1-641289-2
36.07 [1.420]		55.47 [2.184]	47.29 [1.862]	36.47 [1.436]	9	641289-9
24.18 [.952]		43.59 [1.716]	35.41 [1.394]	24.59 [.968]	6	641289-6
12.29 [.484]		31.70 [1.248]	23.52 [.926]	12.70 [.500]	3	641289-3

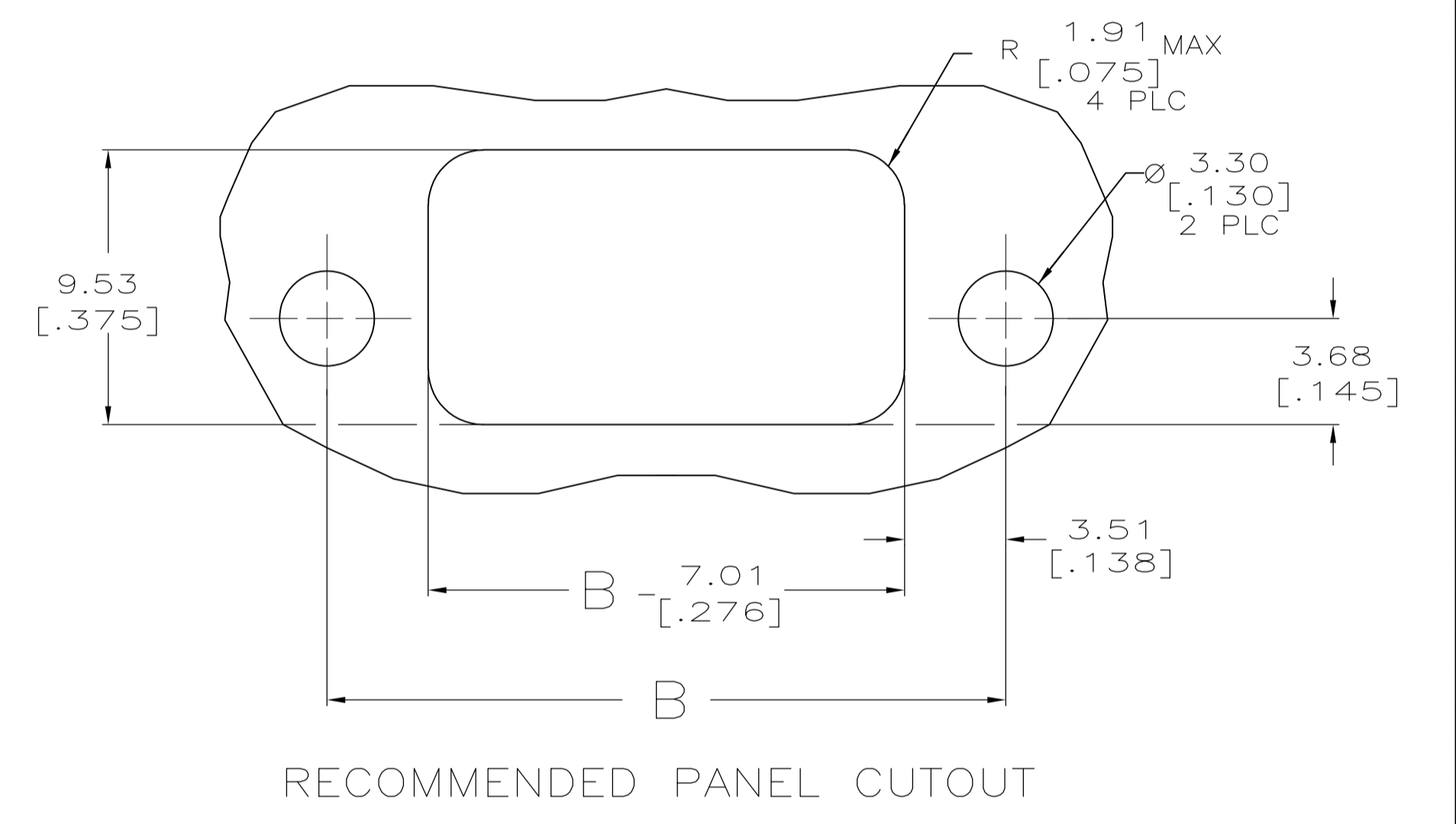
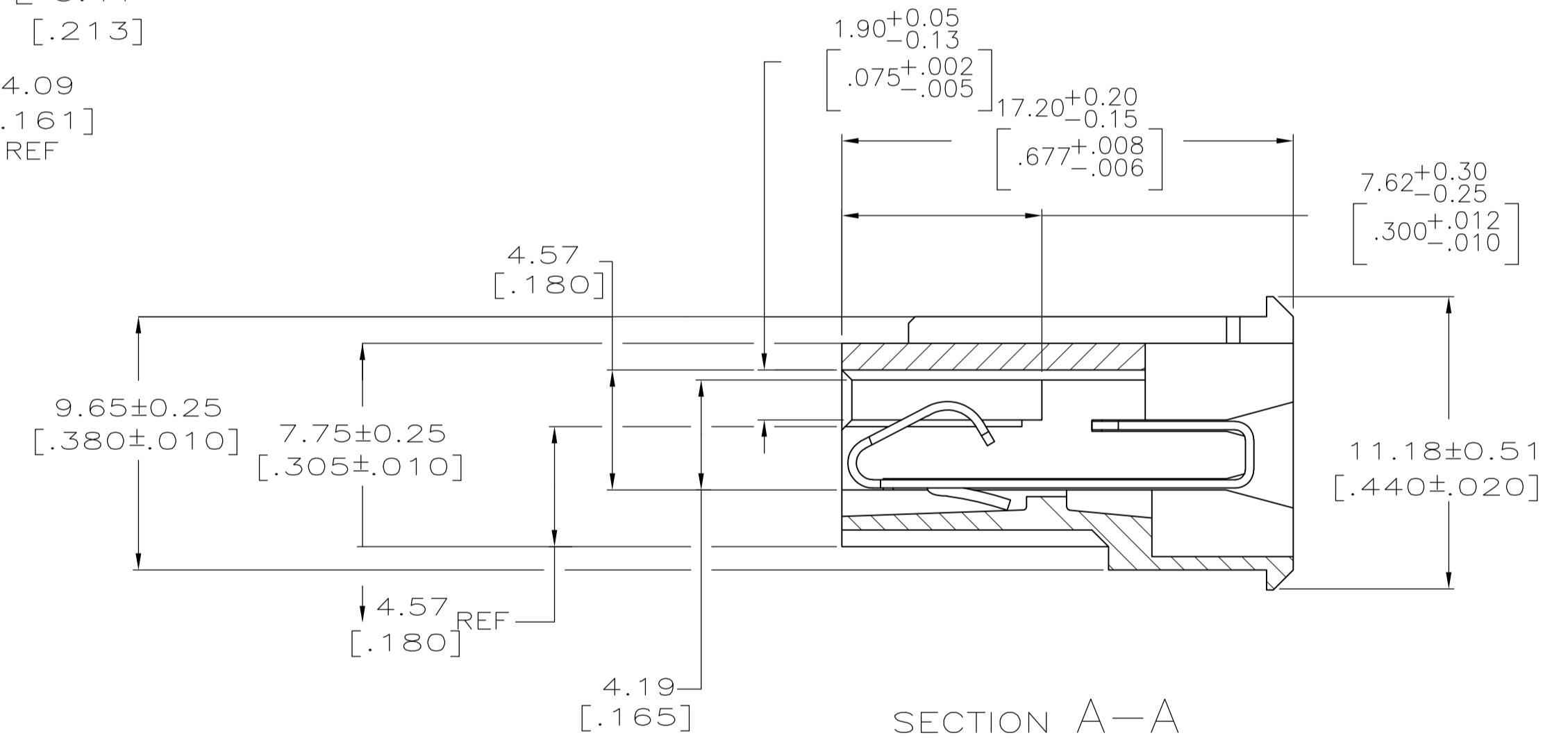
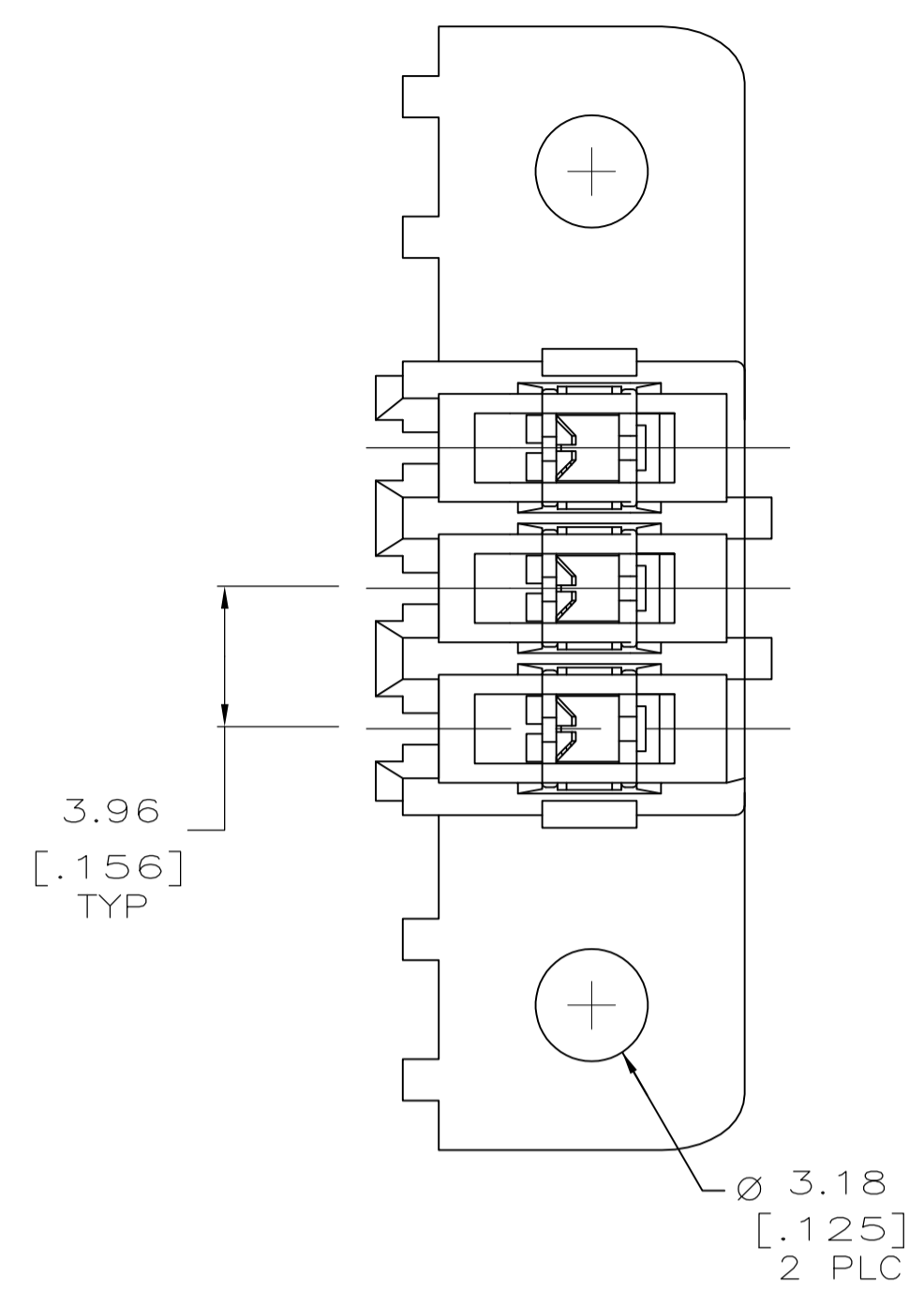
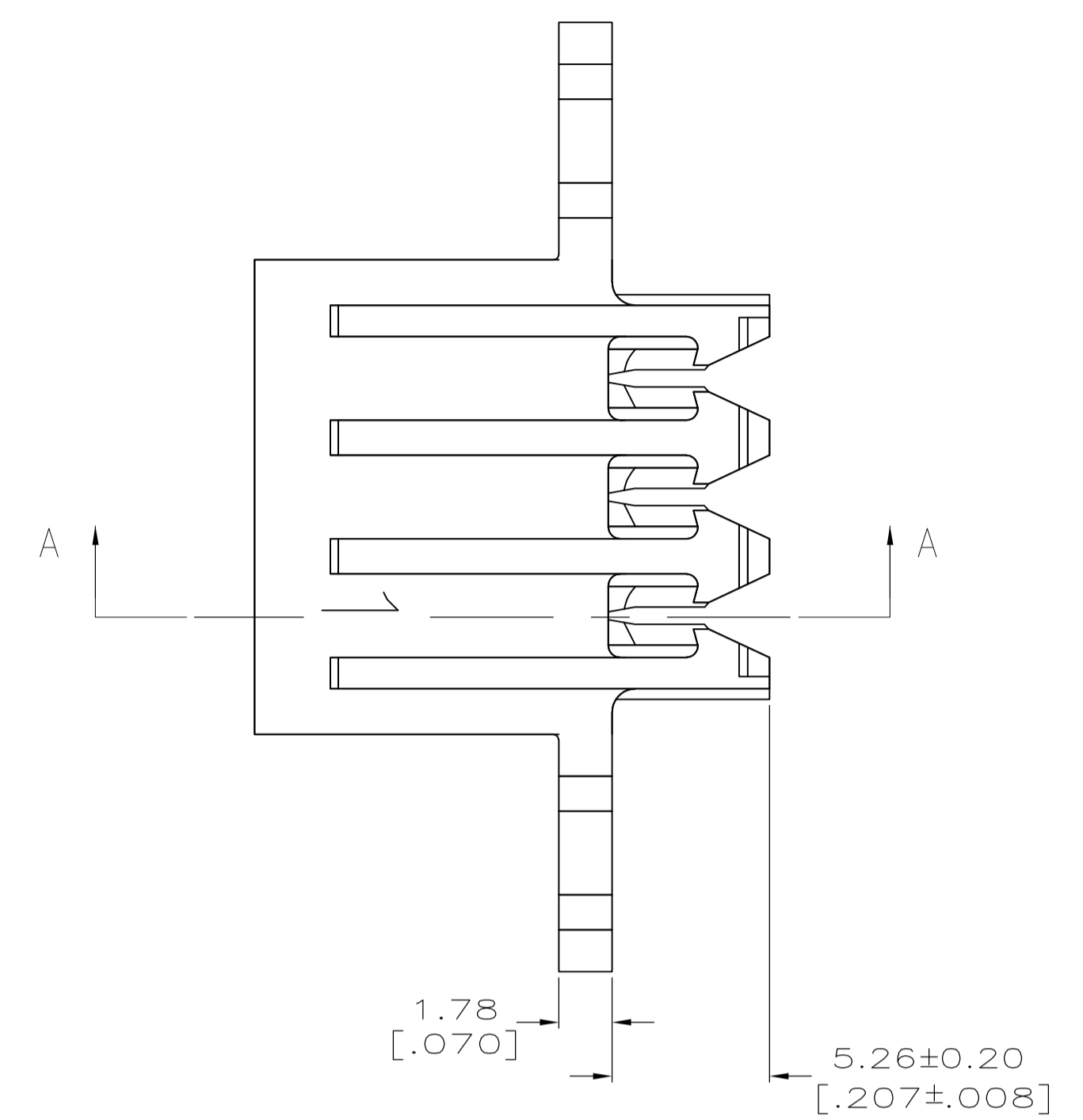
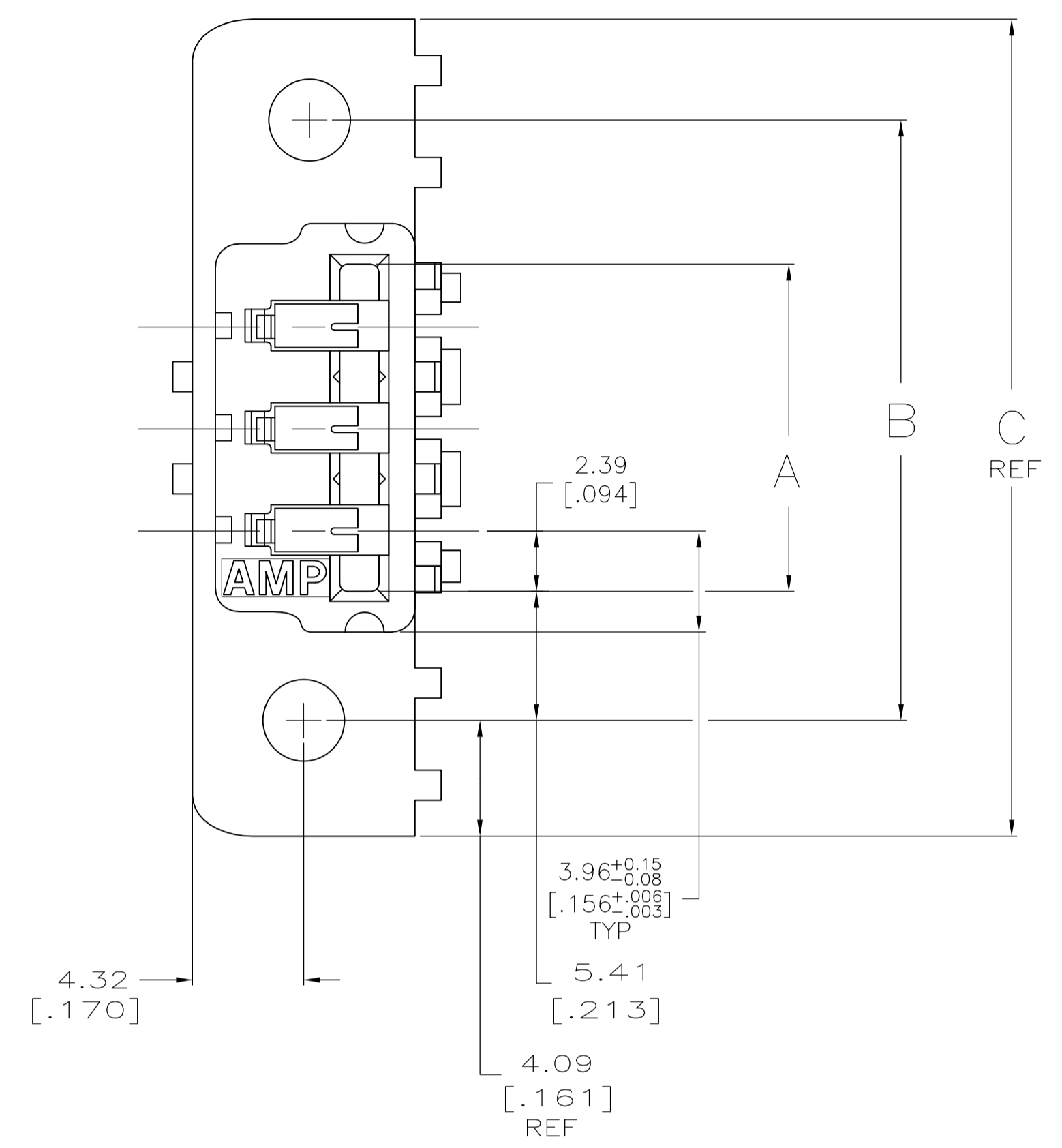
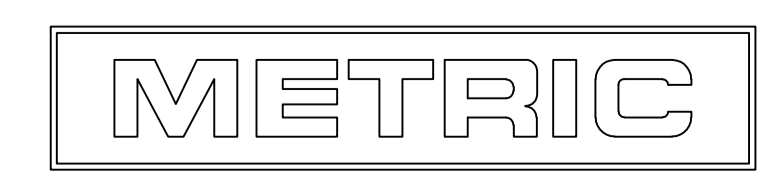

THIS DRAWING IS A CONTROLLED DOCUMENT. DIN B LEWIS 2-22-96
 CJK R SWING 2-22-96

Tyco Electronics Corporation
 Harrisburg, Pa 17105-3608

NAME: MTA-156
 PRODUCT SPEC: CARD EDGE CONNECTOR ASSEMBLY, 20 AWG, PANEL MOUNT

SIZE: A1
 CASE CODE: 00779
 DRAWING NO: 641289

RESTRICTED TO: —
 WEIGHT: —
 CUSTOMER DRAWING: —

SCALE: 5:1
 SHEET: 1 of 1
 REV: G